

401 Legend Lane, Peculiar, MO 64078
 (816) 758-4504 Tech Line
 (816) 758-4512 Fax
 EMail: calkid@casstel.net

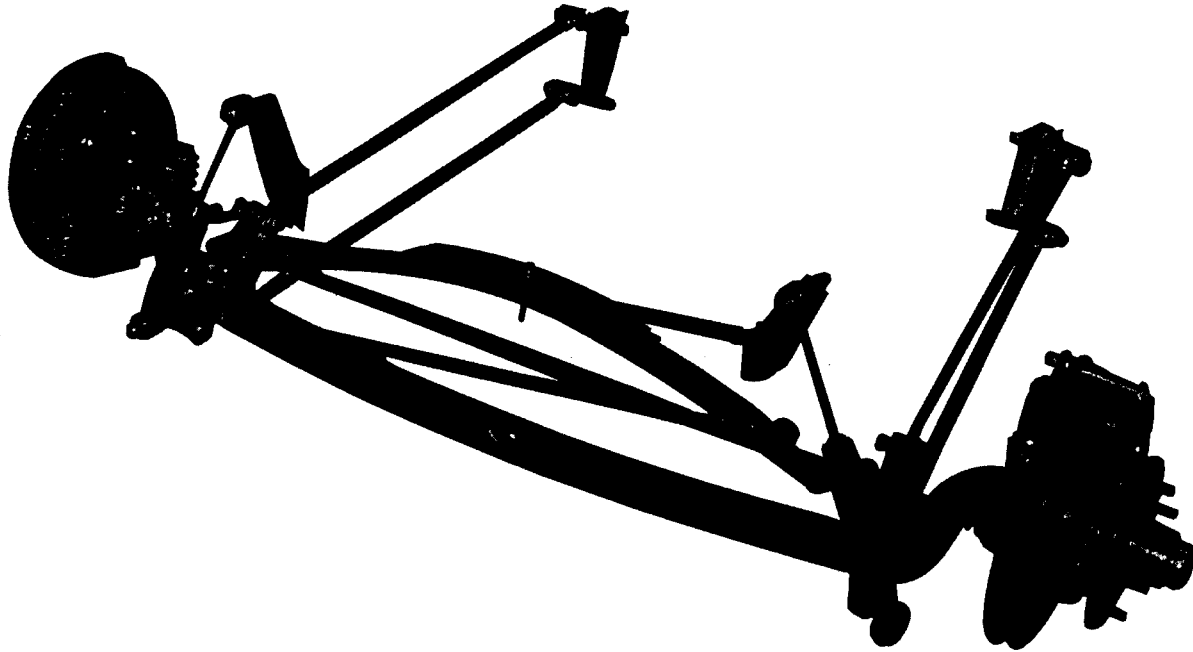

401B Legend Lane, Peculiar, MO 64078
 816-758-5044 Phone
 816-758-5055 Fax
 EMail: superb@casstel.net

Complete 4-Bar™ Front-End Instruction Sheet



NOTE: Before installing your front end, it is recommended that you box your frame the entire length. If boxing the entire length is not possible, it is necessary to partially box your frame rails to the back of the rear 4-Bar™ frame mounts.

1. Before beginning assembly, lay out all pieces where they can be easily seen. It is important that you chase all threads on all bolts using a tap and die, especially if you have purchased any chrome hardware. Also you must use an anti-seizing compound on all threads to avoid having them lock up in the future.
2. First locate the 4-Bar™ mounting bracket, called "batwings" as well as the "lower bolt-ons", and "Spring perches". Begin assembly of the front end by attaching the batwings to the axle using the spring perches and lower bolt-ons. When installed, the lower bolt-ons should face forward, offset to the outside of the car. Do not tighten any bolts/nuts until the entire front end is completely assembled.
3. Install bushings and sleeves in the 4-Bar™ ends as well as the adjustable ends. Thread jam nuts onto the adjustable ends approximately half way to allow for later adjustment thread the adjustable ends onto the rear of the 4-Bars.

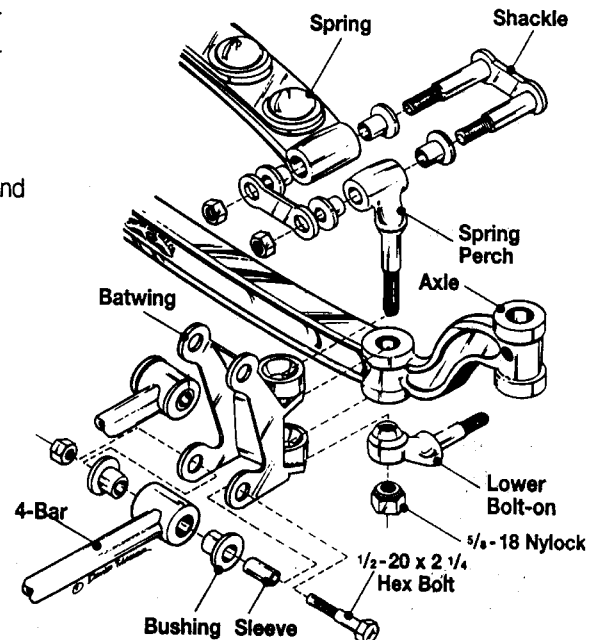

(viewed from passenger front)

4. Mount the spring clamps onto the front leaf spring. Now install the leaf spring onto the front axle using the appropriate shackles and shackle bushings. (Shackle nuts are on the back side.) **NOTE: In order to mount the front axle, it is easiest if the frame is suspended approximately 2 ft. off the ground. Also, it is recommended that some sort of padding is used under the front of the frame during assembly so as to avoid damaging any of the front end parts.**

5. With help from a friend, and a floor jack, raise the axle until the center spring bolt sits in its hole in the center of the front cross member. Mount the spring with the spring shackles. Now adjust 4-Bar™ ends until their hardware fits easily into their appropriate mounting points.

6. Mount your "rod shock" to the "upper shock mount" and "lower bolt-on".

7. Install bushings into the panhard bar, and the adjustable end. Thread the jam nut on approximately half way, and thread the adjustable end onto the panhard bar. Attach the solid end of the panhard bar to the right batwing, and adjust the other until it can be mounted to the frame.

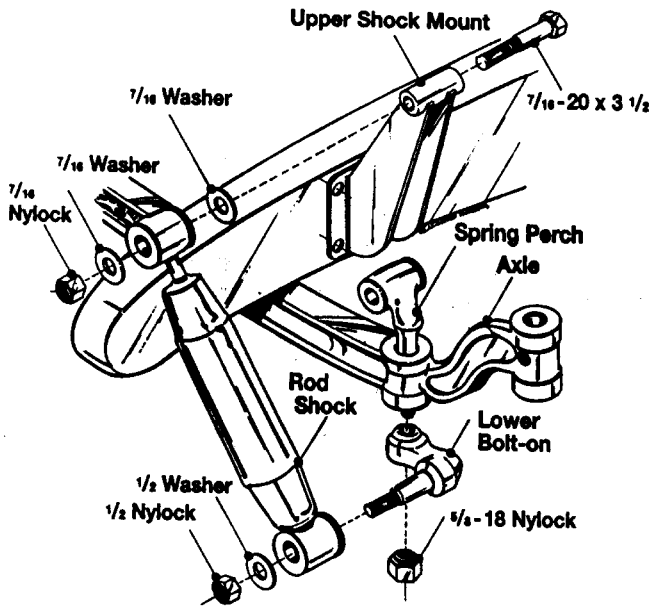
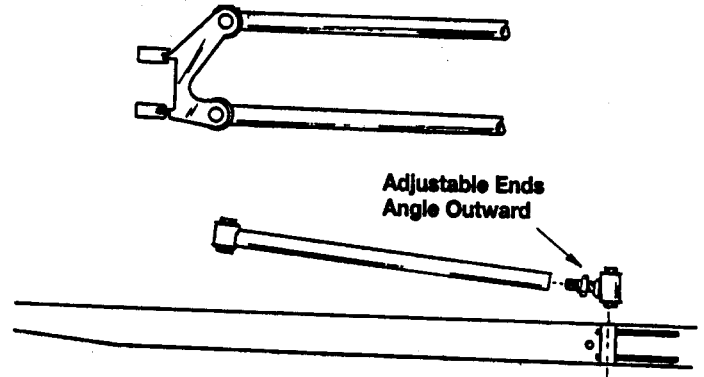

(viewed from driver front)

IMPORTANT The panhard bar, along with the 4-Bars, drag links and tie rods must all be adjusted after complete assembly in order to assure correct ride geometry for your vehicle. Half thread adjustment on adjustable ends is considered a starting point which will allow adequate adjustment in either direction once assembly is complete and the entire weight is on the front end.

8. Locate the correct spindles for each side of the axle, mount them with the kingpins, castle nuts, cotter pins and washers. Grease fittings should face forward for easy access.

9. Install the steering arms. The arm with two holes at the rear is mounted on the right (for cross steer applications).

10. Locate the tie rod, and two tie rod ends. Mount jam nuts onto the tie rod ends half way, and thread the tie rod ends onto both ends of the tie rod. Mount the tie rod in the front most holes of the steering arms. It is recommended that you mount the tie rod ends with the threads pointing up.

11. Locate the drag link and install a tie rod end jam nut on either end. Attach one end to the rear hole of the right steering arm, and the other end to the pitman arm. (Mark sure the steering wheel is in the correct location and the spindles are pointed straight ahead before mounting to the pitman arm.)

12. Mount the disc brake backing plates. Install the rotors and spindle nuts and washers, making sure to grease all bearings. Install the brake callipers with bleeder facing up.

13. Be sure to grease all tie rod ends, and bleed brakes. It is very important that you have an experienced, trained technician align the entire front end in order to avoid premature failure or wear of the front end.

